

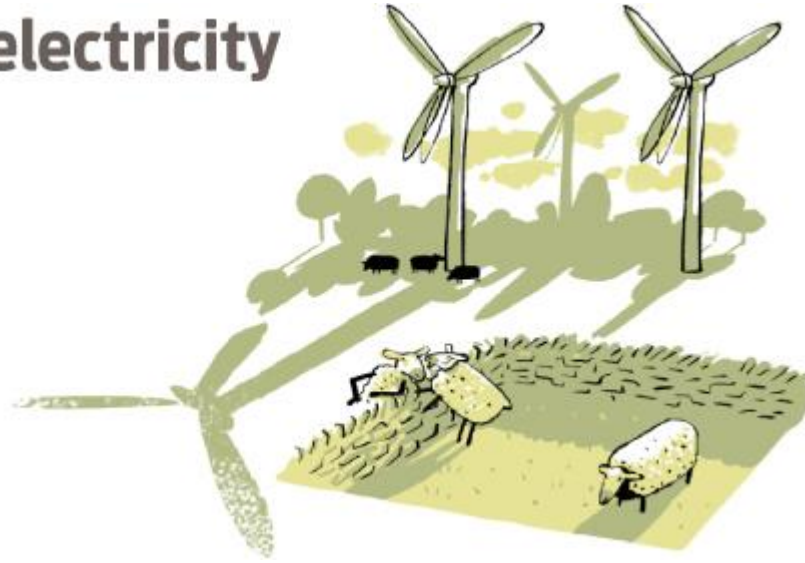

Footprint

The sustainable tv and film company

Our electricity



A case study of 4 x short films,
from development to distribution.



The client

Good Energy is Britain's only 100% renewable electricity supplier. Their electricity comes from wind, hydro and solar power generators across the UK.

Good Energy's mission is to help people reduce their impact on climate change by reducing their CO2 emissions.



The brief

Make four films for online and DVD, showing how people generate power - at home, at work and in the community.

Show the steps people have to take when you switch to micro-generation – from choosing the right technology, to securing grants, getting planning permission and finding an installer.

Make the films clear, informative and honest - to inspire more people to switch to renewable power.

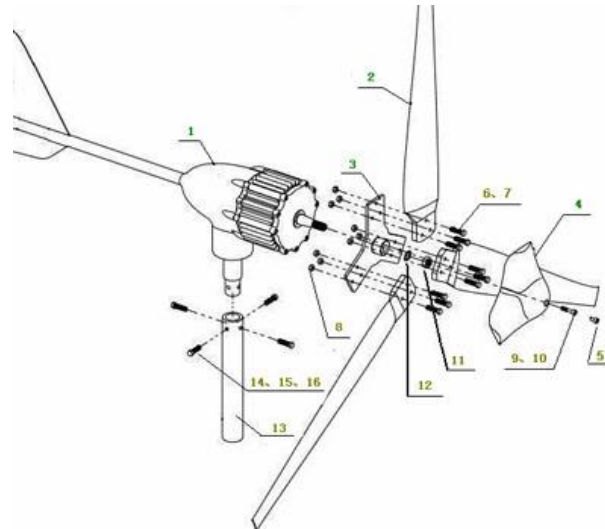

The creative brief

- a) why are we making these films?
- b) what do we want them to say?
- c) who is the audience?
- d) why will they believe them?
- e) what style and tone will we use?
- f) how will the films be distributed?

We worked together via email to develop the brief and held just one client meeting for sign off before production began.



Development

Footprint worked with Good Energy to select a mix of characters for the films - in rural and urban locations, using wind and solar technology.

The case studies were selected to bring each storyline to life – about planning, funding, installation and design. All the research was done via email or over the phone.



Storylines

We filmed each customer for one day to see who they are and how they live.

This documentary filming was mixed with interviews;

- a) customers, talking about switching to micro-generation.
- b) the planning officers, installers and architects who helped.
- c) experts from the Energy Saving Trust. Juliet Davenport talked about industry issues; not Good Energy.



Filming

We used a documentary style so the films felt natural and authentic and told real, believable stories.

To keep our footprint small we used;

- a) four filming days across the whole project.
- b) one-day shoots for each film.
- c) a small film crew - one DOP and one director.
- d) outline scripts, to film efficiently and to keep shot logging, digitizing and editing to a minimum.



Post production

Footprint ran a low carbon edit. We set up a viewing room in Bristol, powered by Good Energy, to shot log the tapes. The tapes, logs and time codes were then sent to the edit suite in Bath.

First drafts were emailed to Footprint, so we could view and make changes remotely. We travelled to the edit suit for the final stage. Only one DVD copy was produced during all of post production.



The launch

The films were first shown at the Delabole Wind Fair in Cornwall. The fair celebrates renewable energy and sustainability.



Distribution

The films were put on the Good Energy website.



green.tv

The films were placed on green.tv - an online channel for environmental films.

In the first two months the films were seen by more than 100,000 people.



green.tv



myspacetv

green.tv syndicated one of the films to myspacetv.

green.tv wrote to Good Energy: “It has been viewed over 10,000 times and is one of our most popular films on the channel. The feedback and comments it is generating are also really positive. This is really good news and hopefully it’s driving traffic your way.”

“one of our most popular films on the channel”

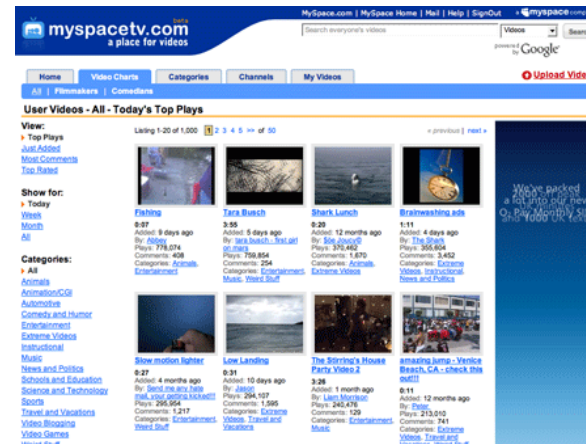

11,731 views
86% rating
58 comments



You Tube



Next was You Tube.

76,000+ viewings, five star ratings and 60+ comments.

Good Energy went on to create their own You Tube channel. The films are featured on this site.



Across the web

The films have been hosted and featured editorially on more than 20 websites including;

- a) Ecostreet
- b) Earth Day Network
- c) Ethical Junction
- d) Earth Project
- e) Energy Research Project.

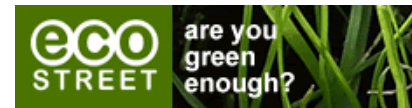

ethical.tv

They were the first films to be shown on the Environment section on ethical.tv - the online channel supported by The co-operative.

The **co-operative**

The screenshot shows the ethical.tv website interface. At the top left is the logo 'ethical.tv' with a blue square containing a white 't'. Below the logo are navigation links: 'Home', 'Channels', 'About', and 'Contact'. On the top right, there is a Facebook icon and the text 'Find us on Facebook'. The main heading is 'Watch something good for a change'. Below this, there is a grid of eight video thumbnails, each with a title, a short description, and a 'View (+)' link.

Thumbnail	Title	Description	View (+)
	Energy from the Community	The problem was an over heated church hall, and the solution: solar paneling replacing the old skylights. A representative from...	View (+)
	Se Vende Justo	The people in this film want to give the fair value to things, work and cultureReflecting on their work in...	View (+)
	Shopping second-hand and vintage - doing it in style!	Write Here, Right Now reporters April and Attia were recently given the challenge of investigating how consumers...	View (+)
	The Shaman's Oil	The Cofan's are an indigenous community living in the Amazonian rainforest. They believe in spirit beings known as 'Coan-Coan' who...	View (+)
	Water is Life	The broadcast report 'Water is Life' shows innovative water and sanitation projects in Kenya, funded with the aid of a...	View (+)
	Thanks For Life: End Polio Now	'Thanks for Life' highlights the humanitarian work of Rotarians with the aim of helping to eradicate polio throughout the world.	View (+)
	Mind the Gap (Vietnam)	With the support of the European Commission through an Italian NGO, the Women's caravan travels through the villages of the...	View (+)
	Lots of Milk!	The Let Agogo (Lots of Milk) project in Haiti assists small scale farmers in producing and selling milk to the...	View (+)



Audiences

The films have generated hundreds of comments and conversations in the UK and around the world.

ahhhhhh....finally a video that touches me in a positive way.

My wife and I are considering an older (1910) farmhouse in Norfolk, Virginia USA and energy conservation is on our minds. Thanks for the information and a little nudge toward our next steps. Peace to you and yours.

I would love to have this installed in my country, (Mexico). Do you think I can get somebody with experience to do it here? Or can install it myself with specific instructions?

Don't give a rats eh? Energy prices are set to rise another 40% this autumn. UK electricity bill is going to leap from an average £1300 to £2600 virtually overnight. Still don't give a rats?

Very interesting & well produced video. Thanks.

What a fabulous home! How much is all of this green technology. And the auto running on solar - can you make a video on the auto?

I really enjoyed this video, it shows the decision making necessary in order to create a sustainable living. Thank you for posting it.

Great story. Many thanks.



DVD

The films were released on DVD.

The packaging is 100% post-consumer recycled board, printed using vegetable-based inks.

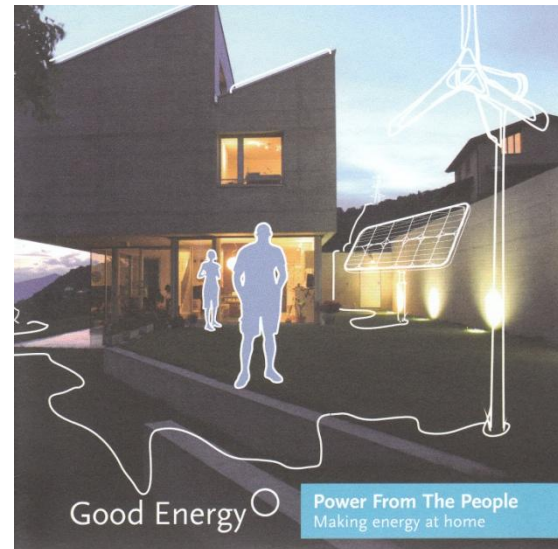

CSR

The films feature in Good Energy's CSR report – 'Living Our Values'.

The report says: "Communication with our customers is key to our business. The inaugural showing of our films on micro-generation was made at the Wind Fair; the films can now be seen on our website."



Press

The films are a resource for Good Energy's press team. Press releases refer journalists to the films online.

The screenshot shows the Good Energy website with a navigation bar at the top. Below the navigation bar, there is a section titled "When we average carbon from" with sub-sections for "Our awards" and "Our awards". The "Our awards" section lists several awards and recognitions, including:

- Our awards**
 - 2011-2012**: Good Energy named Best Big Green electricity.
 - 2011-2012**: Good Energy has been named as Best Big Green electricity by the Green Alliance.
 - 2011-2012**: Good Energy has been named as Best Big Green electricity by the Green Alliance.
 - 2011-2012**: Good Energy has been named as Best Big Green electricity by the Green Alliance.
 - 2011-2012**: Good Energy has been named as Best Big Green electricity by the Green Alliance.
- Our awards**
 - 2011-2012**: Good Energy has been named as Best Big Green electricity by the Green Alliance.
 - 2011-2012**: Good Energy has been named as Best Big Green electricity by the Green Alliance.
 - 2011-2012**: Good Energy has been named as Best Big Green electricity by the Green Alliance.
 - 2011-2012**: Good Energy has been named as Best Big Green electricity by the Green Alliance.
 - 2011-2012**: Good Energy has been named as Best Big Green electricity by the Green Alliance.

The page also features logos for various award organizations such as the Green Alliance, the Green Party, and the Green Deal. At the bottom of the page, there is a footer with the Good Energy logo and the text "GOOD ENERGY" repeated.

To watch Good Energy Home Generators in action and learn more about their projects, visit www.good-energy.co.uk/films.



Juliet Davenport, CEO

“Footprint were charming and efficient and made it their duty to fully embrace a complex subject matter, understand it and communicate it concisely and in a interesting and inspiring way.

A year on we are still delighted with the films and know that they have been highly effective at communicating our work and the important message of climate change. Finally Footprint respected our principles and made a real effort to keep the project as low carbon as possible - something we greatly appreciated.”



To find out how Footprint could develop, produce and distribute your story
please contact:

07875 943 404

scott.jones@footprinttv.co.uk

www.footprinttv.co.uk

